

# Unofficial Property Record Card - Andover, MA

## General Property Data

Parcel ID **89 0 56**  
Prior Parcel ID **0890560 --66**  
Property Owner **NOT AVAILABLE**

Mailing Address

City

Mailing State                      Zip

ParcelZoning **SRB**

Account Number

Property Location **111 RESERVATION RD**

Property Use **ONE FAMILY**

Most Recent Sale Date **1/20/2017**

Legal Reference **17696**

Grantor **HUNT,DONALD W**

Sale Price **0**

Land Area **2.000 acres**

## Current Property Assessment

Card 1 Value    Building Value **493,900**                      Xtra Features Value **53,600**                      Land Value **373,200**                      Total Value **920,700**

## Building Description

Building Style **ANTIQUE**  
# of Living Units **1**  
Year Built **1790**  
Building Grade **GOOD +**  
Building Condition **Good**  
Finished Area (SF) **4528**  
Number Rooms **14**  
# of 3/4 Baths **2**

Foundation Type **BRICKSTONE**  
Frame Type **WOOD**  
Roof Structure **GABLE**  
Roof Cover **WD SHINGLE**  
Siding **CLAPBOARD**  
Interior Walls **PLASTER**  
# of Bedrooms **5**  
# of 1/2 Baths **0**

Flooring Type **HARDWOOD**  
Basement Floor **N/A**  
Heating Type **FORCED H/W**  
Heating Fuel **OIL**  
Air Conditioning **0%**  
# of Bsmt Garages **0**  
# of Full Baths **3**  
# of Other Fixtures **0**

## Legal Description

## Narrative Description of Property

This property contains 2.000 acres of land mainly classified as ONE FAMILY with a(n) ANTIQUE style building, built about 1790 , having CLAPBOARD exterior and WD SHINGLE roof cover, with 1 unit(s), 14 room(s), 5 bedroom(s), 3 bath(s), 0 half bath(s).

## Property Images

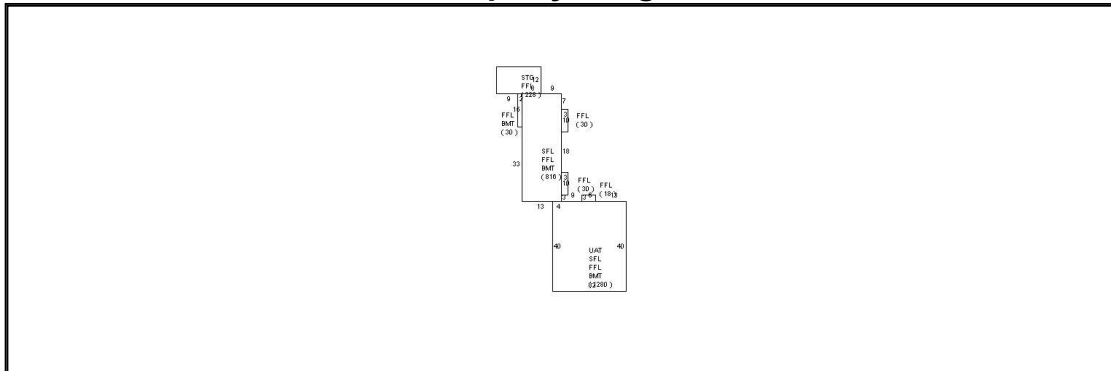

Disclaimer: This information is believed to be correct but is subject to change and is not warranted.

**Building Areas with Alternative Finishes**

<b>Area</b>	<b>Percent Usable</b>	<b>Alternate Type</b>	<b>Alternate Percent</b>	<b>Quality</b>	<b># of Tenants</b>
-------------	-----------------------	-----------------------	--------------------------	----------------	---------------------

**Building Areas**

<b>Sub Area</b>	<b>Sketched Area</b>	<b>Finished Area</b>	<b>Perimeter</b>
BMT	2,126	0	308
FFL	2,432	2,432	440
SFL	2,096	2,096	274
STG	228	0	62
UAT	1,280	0	144